

Project:	Quantity:
Model #:	Approval:

For Commercial Use Only

ENR36G36-N 36" Natural Gas Commercial Range with 36" Griddle Top with Oven



FEATURES

- 60,000 BTU Griddle
- 36" griddle
- Standing pilot light for individual burners
- 30,000 BTU convection oven
- Oven thermostat adjusts from 250F - 500F
- 26.8" x 25.7" x 13" oven cavity
- Manual gas controls with metal knobs
- Stainless steel front, back riser, and lift off shelf
- "Cool-to-the-touch" front s/s deck
- Easy to remove full width crumb tray
- 2 chrome racks included
- Range is fully serviceable from the front
- Legs standard

• cCSAus

• CSA Sanitation



USR Brands is a US supplier of premium quality commercial cooking, refrigeration and food preparation equipment. Our aim is simple. Produce industry-leading commercial restaurant equipment at reasonable prices, and back it all up with an easy to understand, no nonsense warranty that people can count on.

Project:	Quantity:
Model #:	Approval:

For Commercial Use Only

TECHNICAL DATA

DIMENSIONS

Exterior Dimensions	36"L x 32.73"D x 60.36"H
Packaging Dimensions	41"L x 41"D x 38"H
Oven Dimensions	26.8"L x 25.7"D x 13"H
Unit Weight	396 lb.
Shipping Weight	448 lb.

COOKING

Griddle Plate Size	36
Numbers of Ovens	1
Numbers of Oven Racks	2
Oven BTU	30,000
Oven Style	Standard Oven
Max. Oven Temperature	550°F
Total BTU	90,000
Control Type	Maunal
Gas Inlet Size	3/4"
Power Type	Natural Gas

CONSTRUCTION

Exterior Material	Stainless Steel
Frame Structure	Welded
Pull Out Tray	"Yes"

DIAGRAM

MODEL: ENR36G36-N

MFR MODEL: ENR36G36-N

Front View

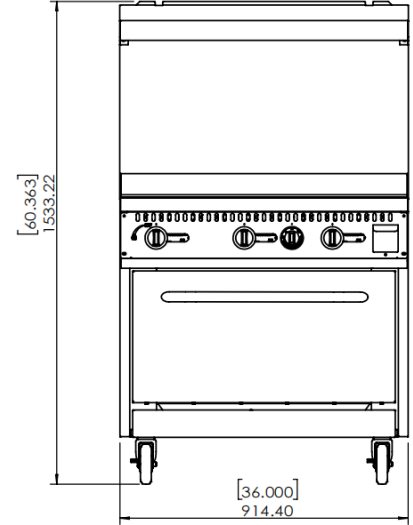

Side View

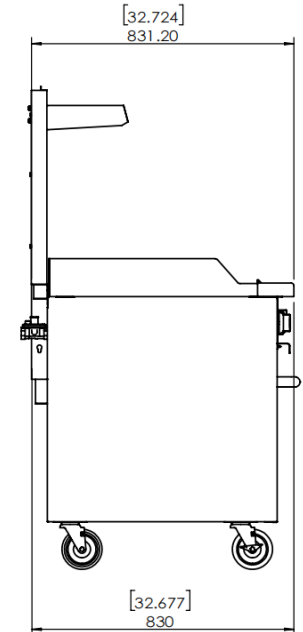

Top View

