

ISLAND-DT60 62" Open Air Dual Temperature Refrigerated and Freezer Island Merchandiser



FEATURES

- 62" horizontal island open air refrigerator / freezer
- Easy to use digital temperature controls
- Dual-temperature system with push-button switching
- Refrigeration Temp range: 32 - 41 degrees F
- Freezer Temp range: -8 - 0 degrees F
- Automatic defrost
- 4 pre-installed low-profile casters, 2 leveling feet
- Hydro-Carbon R290 refrigerant
- 7.88" interior height, 4" straight glass on four sides
- Includes stainless steel bumper guards on all sides
- Self-contained refrigeration system
- 120V plug and play design, NEMA 5-30P

- cETLus Listed
 - ETL Sanitation Listed
- Certified to **NSF** Standard



USR Brands is a US supplier of premium quality commercial cooking, refrigeration and food preparation equipment. Our aim is simple. Produce industry-leading commercial restaurant equipment at reasonable prices, and back it all up with an easy to understand, no nonsense warranty that people can count on.

Project:	Quantity:
Model #:	Approval:

For Commercial Use Only

TECHNICAL DATA

DIMENSIONS

Exterior Dimensions	62.2"W x 41.2"D x 35.8"H
Interior Dimensions	51.2"W x 29.2"D x 8"H
Packaging Dimensions	64.6"W x 42.5"D x 47.2"H
Net Volume	7.4 cu. ft.
Unit Weight	448 lb.
Shipping Weight	496 lb.

ELECTRICAL

Voltage	110
Hertz	60
Phase	1
Refrigerator / Freezer Amps	14.8A / 23.6A
Plug Type	NEMA 5-30P
Available Power Cord Length	70"

COOLING

Refrigerator Temp Range	33°F - 42°F
Freezer Temp Range	-8°F - 0°F
Refrigerant	R290
Defrosting	Automatic
Temperature Controller	Digital
Horsepower	(2) 1

CONSTRUCTION

Exterior Material	Coated Steel
Interior Material	Painted Steel
Pre-Installed Casters	Yes

TECHNICAL DRAWING

MODEL: ISLAND-DT60

MFR ITEM #: KIF-P1510TB



NEMA 5-30P
(30A circuit required)

FRONT VIEW

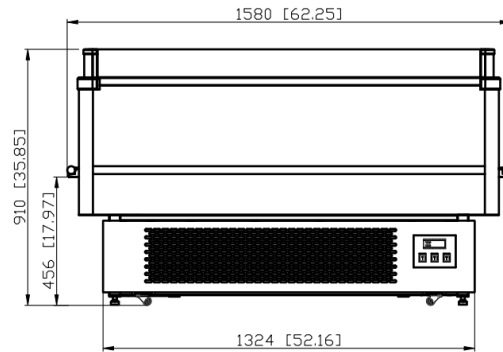

SIDE VIEW

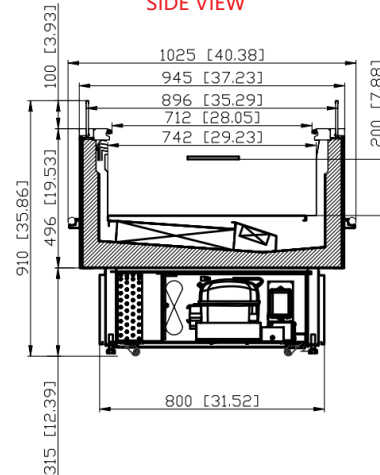

TOP VIEW

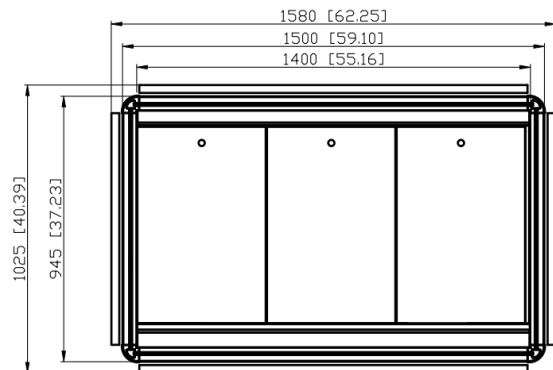

- Designed to operate in locations not exceeding 75°F and 55% relative humidity.