

Project Name: \_\_\_\_\_ AIA#: \_\_\_\_\_

Model #: \_\_\_\_\_ Location: \_\_\_\_\_

SIS#: \_\_\_\_\_ Item #: \_\_\_\_\_ Quantity: \_\_\_\_\_



# Premium Heavy-Duty Manual Slicers

## Models

- 3600N     3600N-22060 Special voltage\*
  - 3600N-22050 Export only, special voltage\*\*
- Consult factory for more information*

### Standard Features

#### Premium Construction

- 13" *PreciseEdge™* hardened steel alloy knife blade with maximum tip-edge-holding ability
- Stainless steel construction with superior corrosion resistance against acids found in fruit, meats and vegetables
- Best of the Best, *EZ-Glide™* slice system
- No-drip base with Marine edge — 1/2" to 3/4" wide and indented areas with 3/16" deep radiused transition and 3/16" deep internal coved corners — redirects liquid to center of base away from controls and operator
- Precise slice-thickness adjustment, one-piece handle, gear driven and gasket-sealed
- Carriage angle: 45°, full gravity feed
- 2° angled drip groove on slicer table directs liquid flow to base
- 12" long chute with 3 lb. stainless steel end weight
- Powerful 1/2 HP, 7 amp continuous use motor
- High-performance gear knife drive
- Maintenance-free drive system
- No voltage release prevents inadvertent reactivation of slicer in the event of power or interlock interruption
- Permanently attached knife blade ring guard with removable cover and deflector
- Knife cover interlock prevents slicer from operating without the knife cover in place
- Knife sharpening system is removable and BPA Free (no-bisphenol-A), immersible, and dishmachine-safe for cleaning and sanitizing
- Touch pad start/stop controls, power indicator light
- Ergonomic low-profile design reduces operator fatigue
- Kick-stand for cleaning and sanitizing under slicer

### Warranty

- **15-years on knife drive gears**
- **Two-years parts and one-year labor**

*Warranty valid in North America, contact factory regarding warranty in other countries*

### Factory options and accessories:

**To select factory installed options and accessories see back**



**Precise - Powerful - Premium Construction.** Gear-driven, hardened steel, alloy knife and corrosion resistant stainless steel construction.



### Standard Features

#### Food Zone

- Large stainless steel radii, open space base design for cleaning and simple dismantling of components
- Knife sharpening system is removable and BPA Free (no-bisphenol-A), immersible, and dishmachine-safe for cleaning and sanitizing
- Moisture proof, easy-to-clean direct contact start/stop touchpad controls
- Sealed splash zones for added sanitation and protection of electronics



*\*Special voltage slicer, non-returnable*

*\*\*Special voltage slicer, non-returnable — export only, consult factory for more information*

Approved by: \_\_\_\_\_ Date: \_\_\_\_\_

2153 Dryden Rd., Dayton, OH 45439 | 937-299-5493 | 800-347-5423 | Fax: 937-299-4147 | www.globefoodequip.com



# Premium Manual Slicers 3600N / 3600N-22060 / 3600N-22050

Elevation / Front View

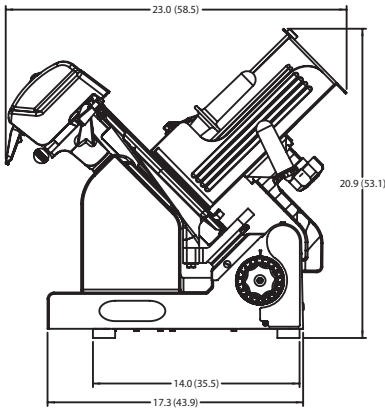

Side View

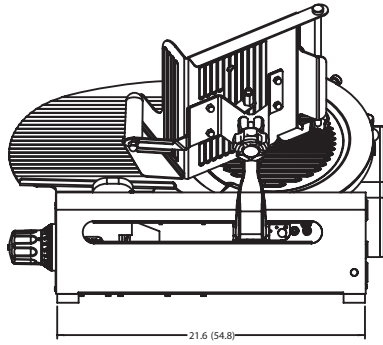

Plan / Top View

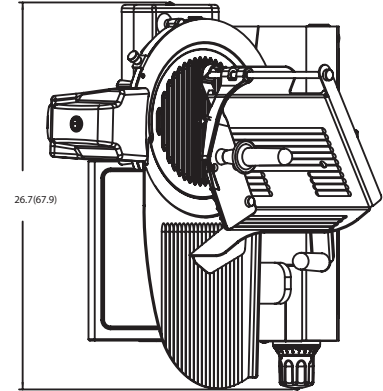

Elevation / Front View with 3" extension legs

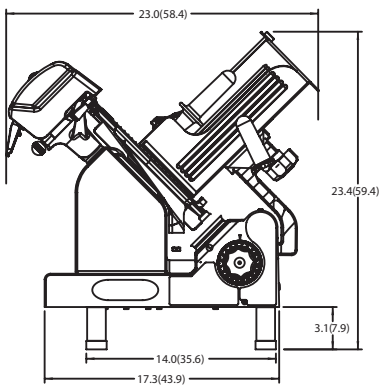

Side View/Kickstand

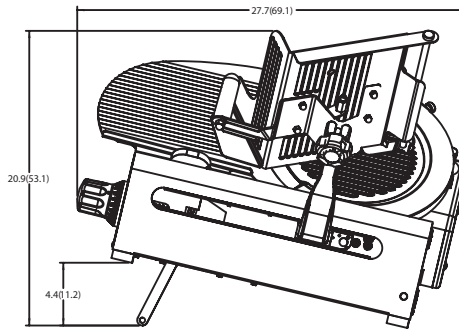

Note: different chute options will change overall height

Drawings available through KCL. [www.kclcad.com](http://www.kclcad.com)

## SPECIFICATIONS

Model	Motor	Volts	Amps	NEMA Plug Type	Drive Type	Slicing Vol. / Day	Cheese Slicing	Blade Diameter	Max Slice	Product Cutting Capacity			
										D (Diameter)	W (Width)	H (Height)	
3600N	1/2 HP	115-60-1	7	5-15	⊕	Gear	All Day	100%	13" (33.02 cm)	1-1/4" (3.18 cm)	7.5" (19.50 cm)	11.6" (29.46 cm)	9" (22.86 cm)
3600N-22050	1/2 HP	220-50-1	3.5	CEE 7/7	⊕	Gear	All Day	100%	13" (33.02 cm)	1-1/4" (3.18 cm)	7.5" (19.50 cm)	11.6" (29.46 cm)	9" (22.86 cm)
3600N-22060	1/2 HP	220-60-1	3.5	6-15P	⊖	Gear	All Day	100%	13" (33.02 cm)	1-1/4" (3.18 cm)	7.5" (19.50 cm)	11.6" (29.46 cm)	9" (22.86 cm)

**Cord & Plug:** Attached 7 ft. flexible 3-wire cord with molded plug fits a grounded receptacle. **Please specify desired plug configuration when ordering.**

**Please note: Special voltage slicers are non-returnable**

## DIMENSIONS | SHIPPING INFORMATION

Reinforced carton for shipping. The weight and dimensions of this reinforced carton are included below and may vary from shipment to shipment.

**Shipped on a pallet. Freight class 77.5.**

Model	Foot Print	Overall Dimensions	Net Weight	Shipping Dimensions	Shipping Weight
3600N 3600N-22050 3600N-22060	21.6" W x 14" D (55 cm x 35.5 cm)	23" W x 26.7" D x 20.9" H (58 cm x 68 cm x 53.1 cm)	112 lbs. (50.8 kg)	25" W x 28" D x 28" H (63.5 cm x 71 cm x 71 cm)	132 lbs. (60 kg)

### FACTORY INSTALLED OPTIONS:

- QUICK-CLEAN™** Proprietary non-stick nickel-based coating (knife cover and slicer table)
- Dual arm lift lever for easy cleaning
- CORR** Correctional package
- MEATROOM** High moisture application package (includes 13" stainless steel knife)
- LONGCHUTE** 15" long food chute
- SSK** 13" long stainless steel knife

### OPTIONAL ACCESSORIES:

- 1047** Stainless steel low food fence (12" L x 1 3/8" H)
- 1326** Stainless steel high food fence (12" L x 3" H)
- 873-SET** 3" extension legs (set of 4)
- 699-BAS** Stainless steel vegetable hopper (14" L x 7" D)
- SC-LARGE** Clear plastic slicer cover (recommended for preconstruction)
- CB** Additional cleaning brush